



Bells and

Bellframes



St Gwynhoeld, Gwynedd
C9th handbell

Birnie handbell, Nairn C9th



C9th MSS
depicting bell-
ringing

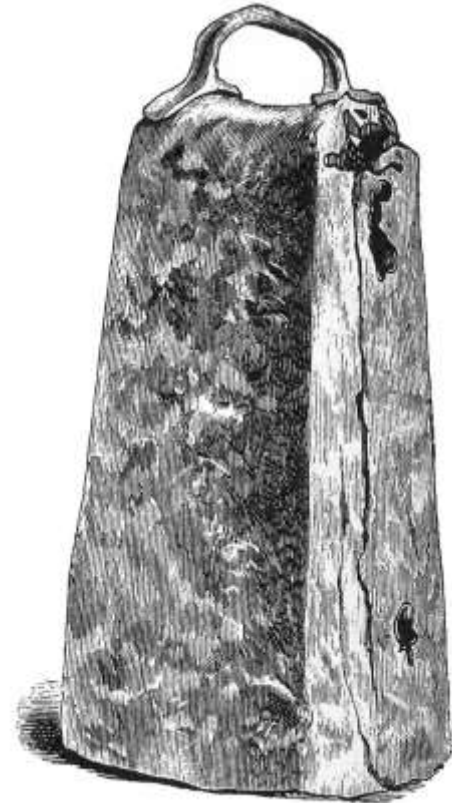



Crowland Abbey,
Lincolnshire

Had a peal of
seven bells by AD
984

Uses of bells:

Monastic - use of small bells in the liturgy = probable earliest use
- ringing the canonical hours

Parochial - calling to worship
- announcing the elevation of the host (Sanctus)
- tolling for the dead

Secular - warning signals for invasion (medieval and modern)
- sounding the time
- superstition
- change ringing (post-Reformation)



Stoke Dry, Rutland: C12th bell ringer on chancel arch pier

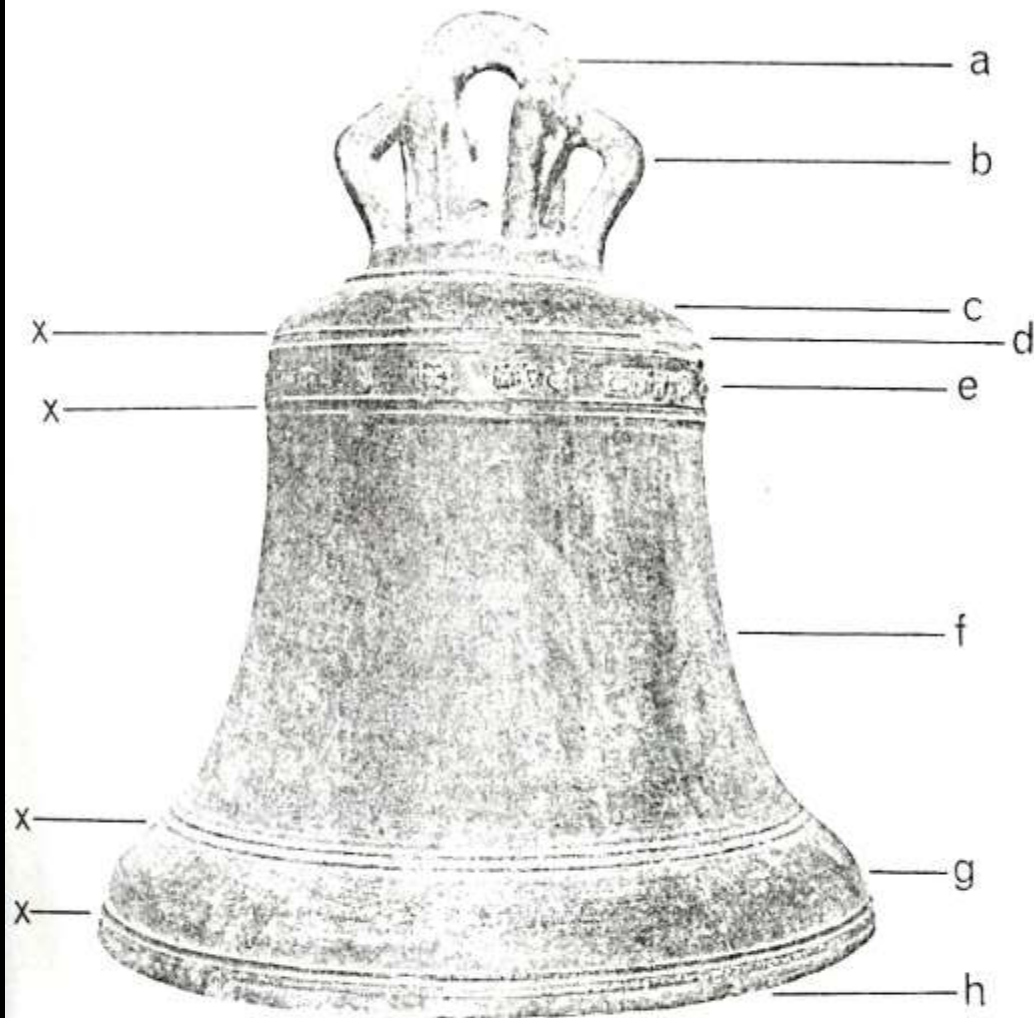

Photo:

F. Sharpe

Yazor, Herefordshire. Fourteenth century bell.

- | | | |
|------------|----------------------|--------------------|
| a. Argent. | d. Shoulder. | g. Sound-bow. |
| b. Canons. | e. Inscription band. | h. Lip. |
| c. Crown. | f. Waist. | x. Moulding wires. |



Littleborough, c.1180. Inscribed 'Sca. Maria'
– medieval bells were often dedicated to a saint



Moorhouse c.1240
uninscribed



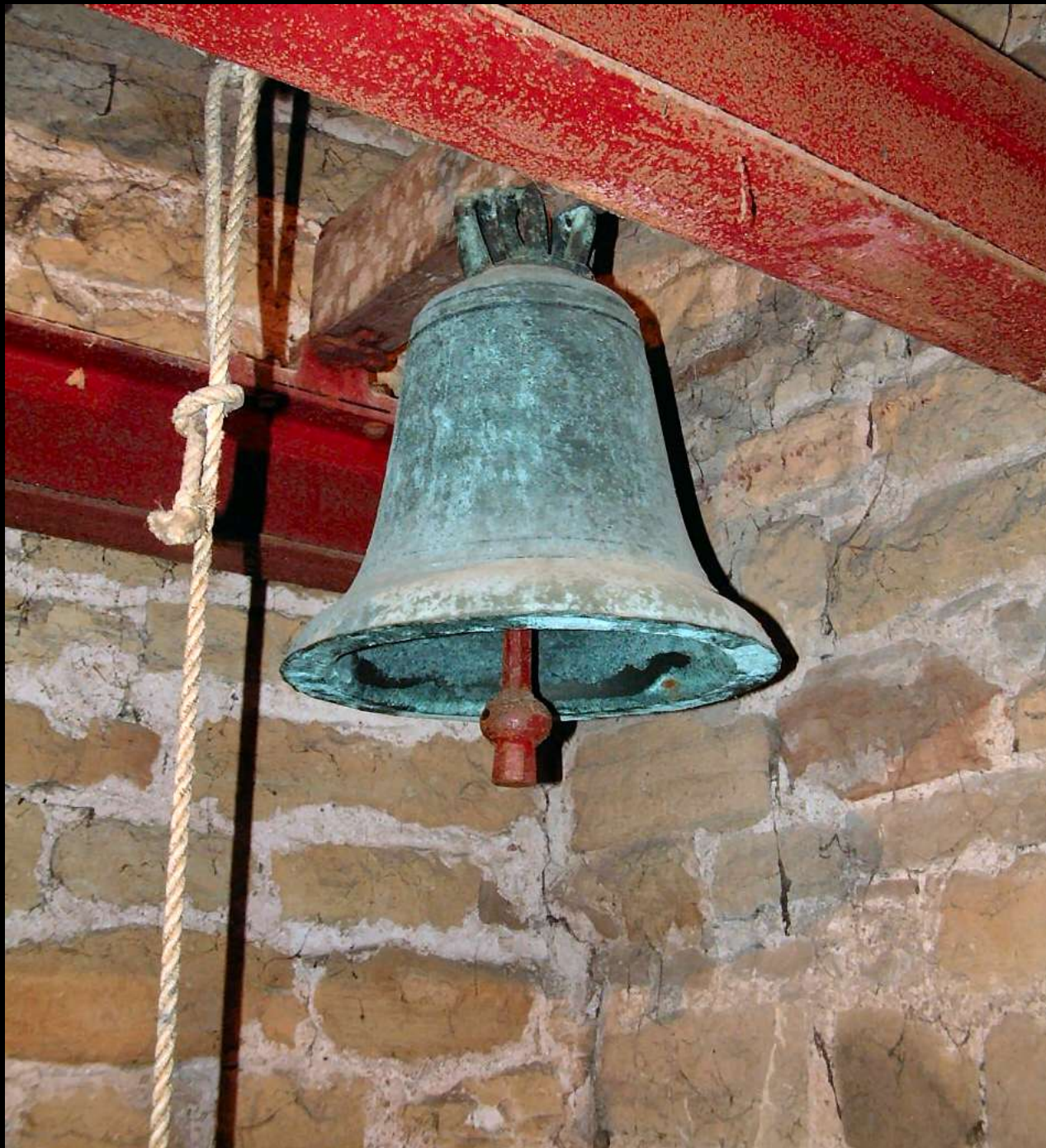

Halam c.1250
uninscribed



Weston:
Sacring
bell
17thC

CROWN.

- ✓ STOKENHAMS C 1325
- ✓ PLAINMOOR TOWER C 1325
- ✓ KILN BRIDGE TRINITY C 1350
- ✓ ELSTON TOWER - C 1350
- ✓ HOWK CURETH
- ✓ FORTON TOWER C 13 CENT
- ✓ ELSTON TRIFALE

WESTON ON TARRANT
PLATE
C 1520

NOTTINGHAMSHIRE BELLS.

MOUTH.

TRAPEZIODS.

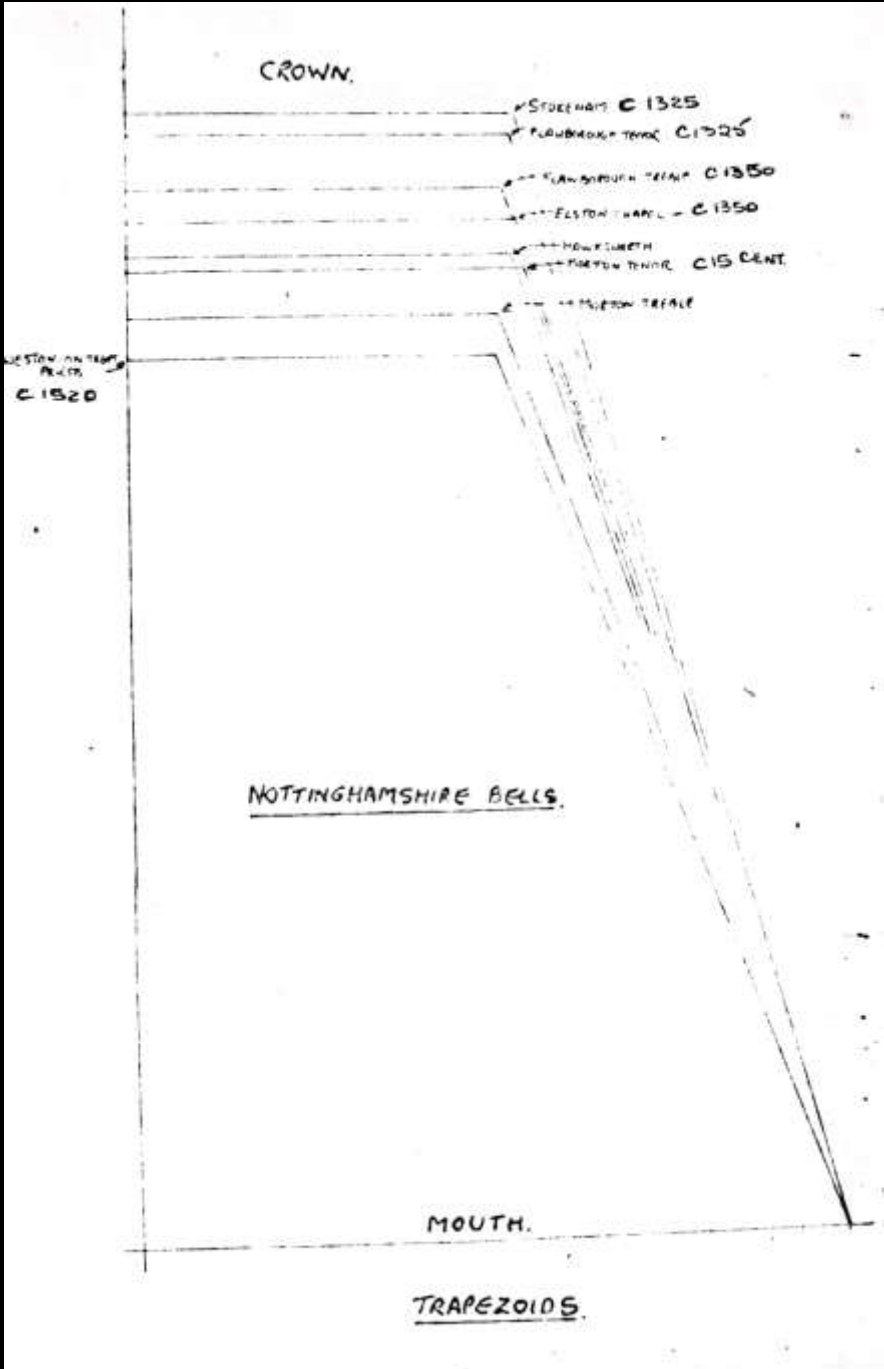

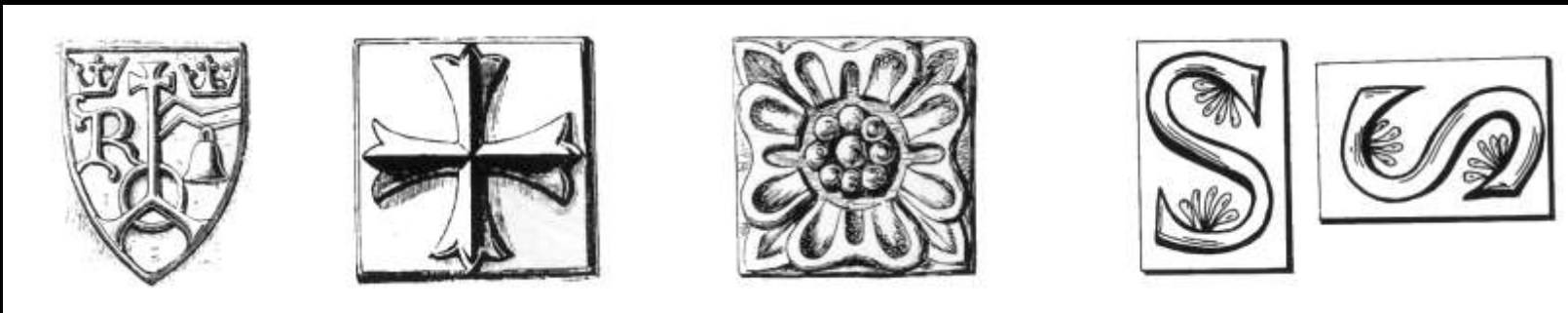

Founder's Marks: Richard & Robert Mellour, Nottingham,
c1470-1525

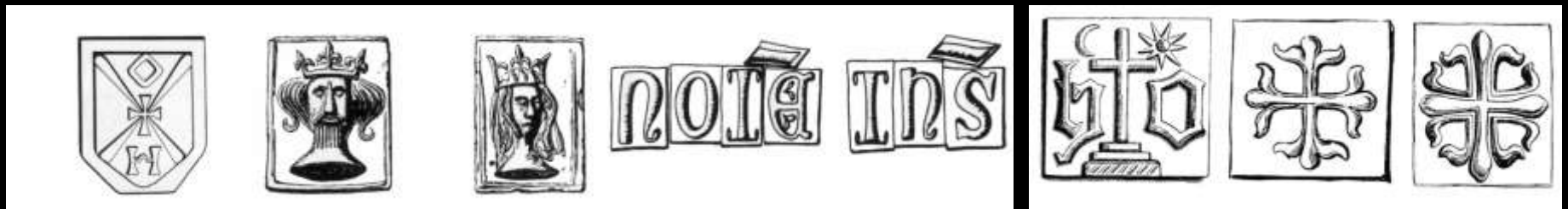

Founder's Marks: Henry I Oldfield, Nottingham c.1540-90

a e g h t w y

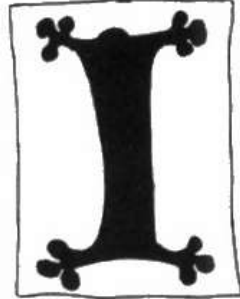
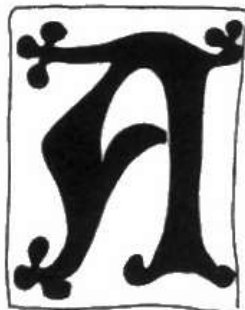

Lettering style: Henry II Oldfield, Nottingham, 1590-1620



Founder's marks and badges used by Taylor of Loughborough, 1839-present



Cromwell: George I Oldfield
Nottingham 1622



Bothamsall: William Seller
York 1685



Worksop Priory: Thomas Mears
London 1843



Huthwaite: Barwell
Birmingham 1903







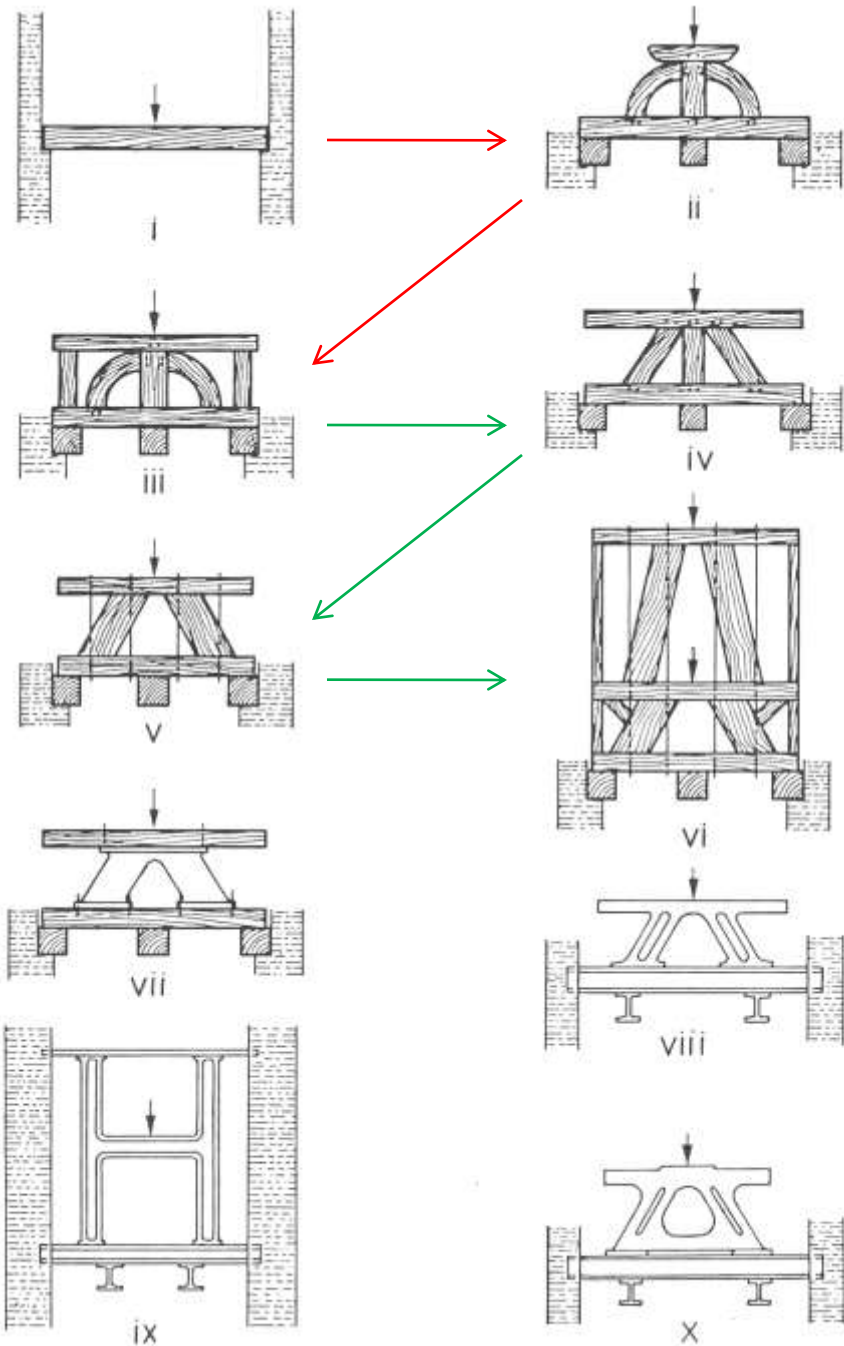

South Leverton: previously unrecorded late medieval ladder

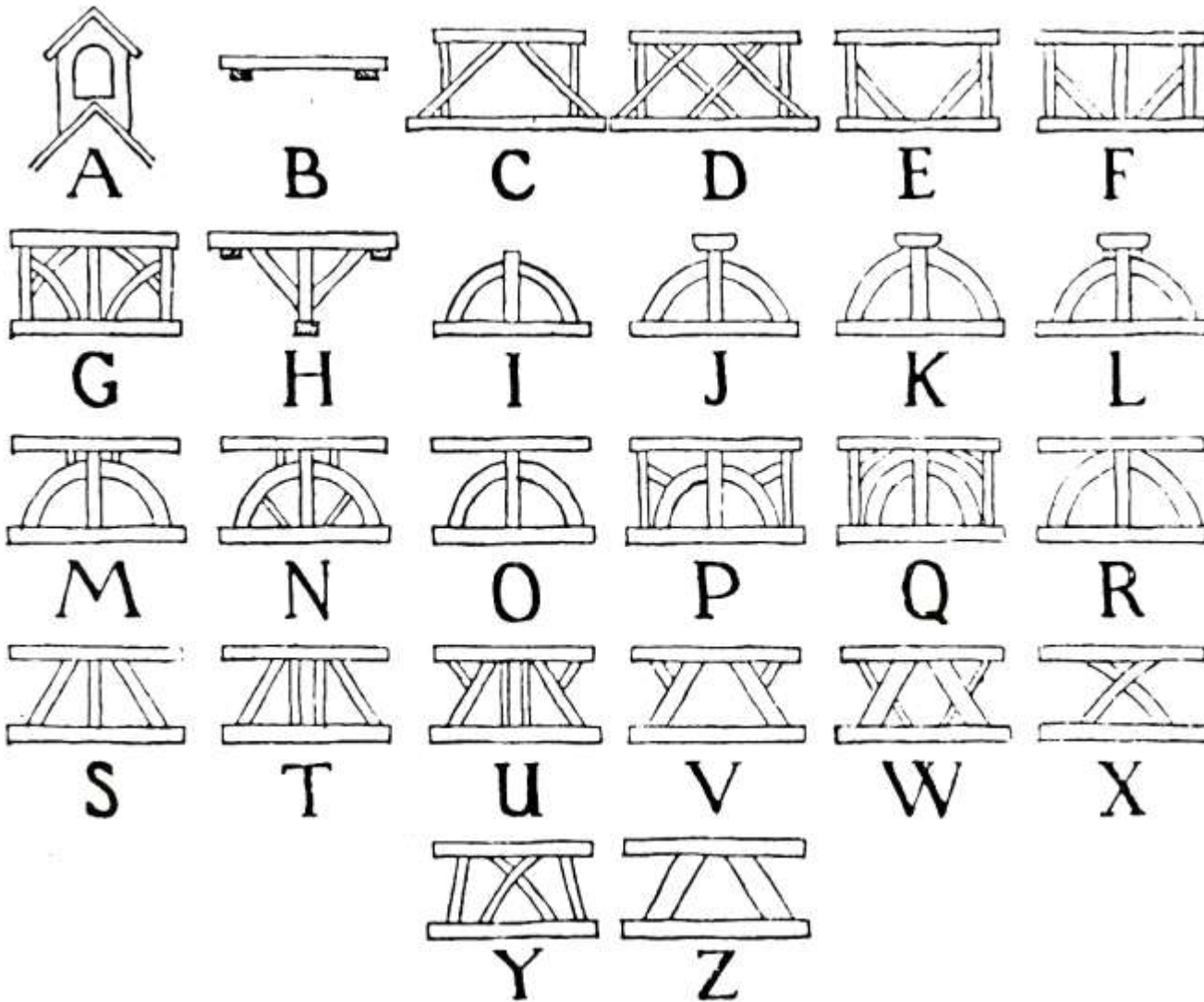

Approximate evolution
of the bell frame

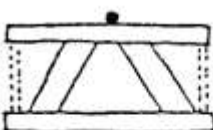
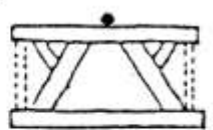
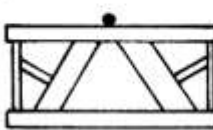
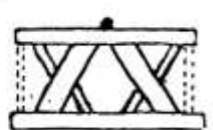
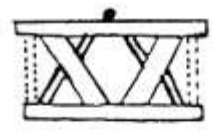
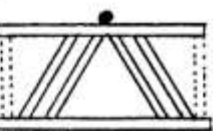
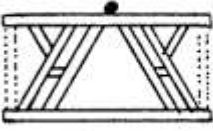
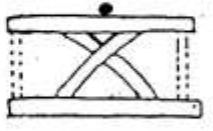
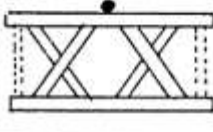
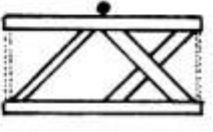
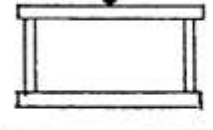
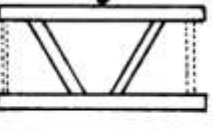

George Elphick's 1945 classification of bell frames

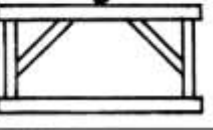
<p>6.A</p> 	<p>sill, long head, and braces from sill to head (Elphick Z)</p>	<p>6.B</p> 	<p>sill, long head, braces from sill to head, and jack braces from brace to head (Elphick V - a jack-braced frame)</p>
<p>6.C</p> 	<p>sill, long head, end posts, braces from sill to head, and jack braces from braces to end posts</p>	<p>6.D</p> 	<p>sill, long head, braces from sill to head, and jack braces from braces to head and from sill to braces (Elphick W - a double jack-braced frame)</p>
<p>6.E</p> 	<p>sill, long head, outward braces from sill to head, and jack braces from sill to braces and from braces to head (an inverted double jack-braced frame)</p>	<p>6.F</p> 	<p>sill, long head, and pairs of parallel braces from sill to head</p>
<p>6.G</p> 	<p>sill, long head, pairs of parallel braces from sill to head, jack braces to head, and horizontal struts between braces</p>	<p>6.H</p> 	<p>sill, long head, and intersecting braces ("X" braces) from sill to head (Elphick X and Y)</p>
<p>6.I</p> 	<p>sill, long head, and pairs of intersecting braces ("X" braces) from sill to head (a double "X" braced frame)</p>	<p>6.J</p> 	<p>asymmetrical truss with sill, long head, one brace from sill to head, and a pair of intersecting braces (an "X" brace) from sill to head</p>
<p>6.K</p> 	<p>sill, long head, and end posts</p>	<p>6.L</p> 	<p>sill, long head, and braces outwards from sill to head</p>
<p>6.M</p> 	<p>sill, long head, end posts, and braces from sill to end posts (Elphick E)</p>	<p>6.N</p> 	<p>sill, long head, end posts, and braces from end posts to head</p>

Chris Pickford's 1993 re-classification

- Here showing Group 6 typology



Bleasby. Simple Elphick 'B' frame suspended between belfry window cills. Tree-ring dated to AD 1476



B



Halam – original Elphick 'B' frame
(now not in use). Undated
probably
late medieval or C17th.



Kilvington – original fir 'B' frame
of 1852



B



Heapham, Lincolnshire:

A very rare example of an
Elphick 'H' frame / Pickford
Group 1 variant viii

Undated but potentially very
early medieval

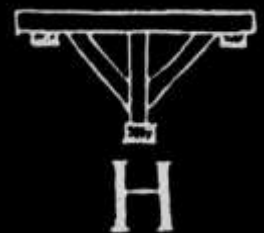

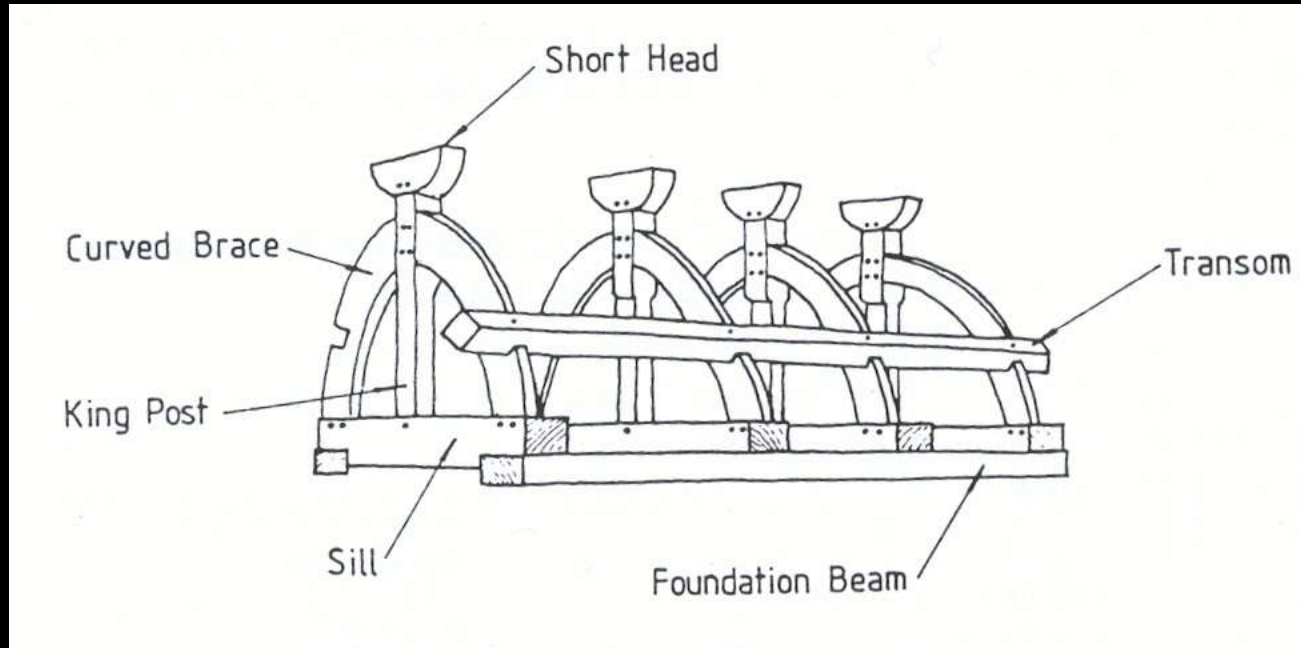

Short-headed frames (mainly medieval)



Lambley: short-headed frame, Pickford type 3.G variant.

Tree-ring dated to AD 1475.

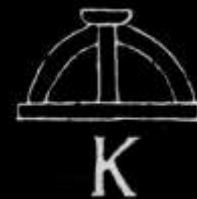



Carlton-on-Trent: short-headed frame (Elphick 'K' /
Pickford 3.D. variant) in a C19th tower

Tree-ring dated to AD 1547





Morton: Pickford type 3.E variant short-headed bellframe formerly in C18th tower.
Undated but probably from previous church.



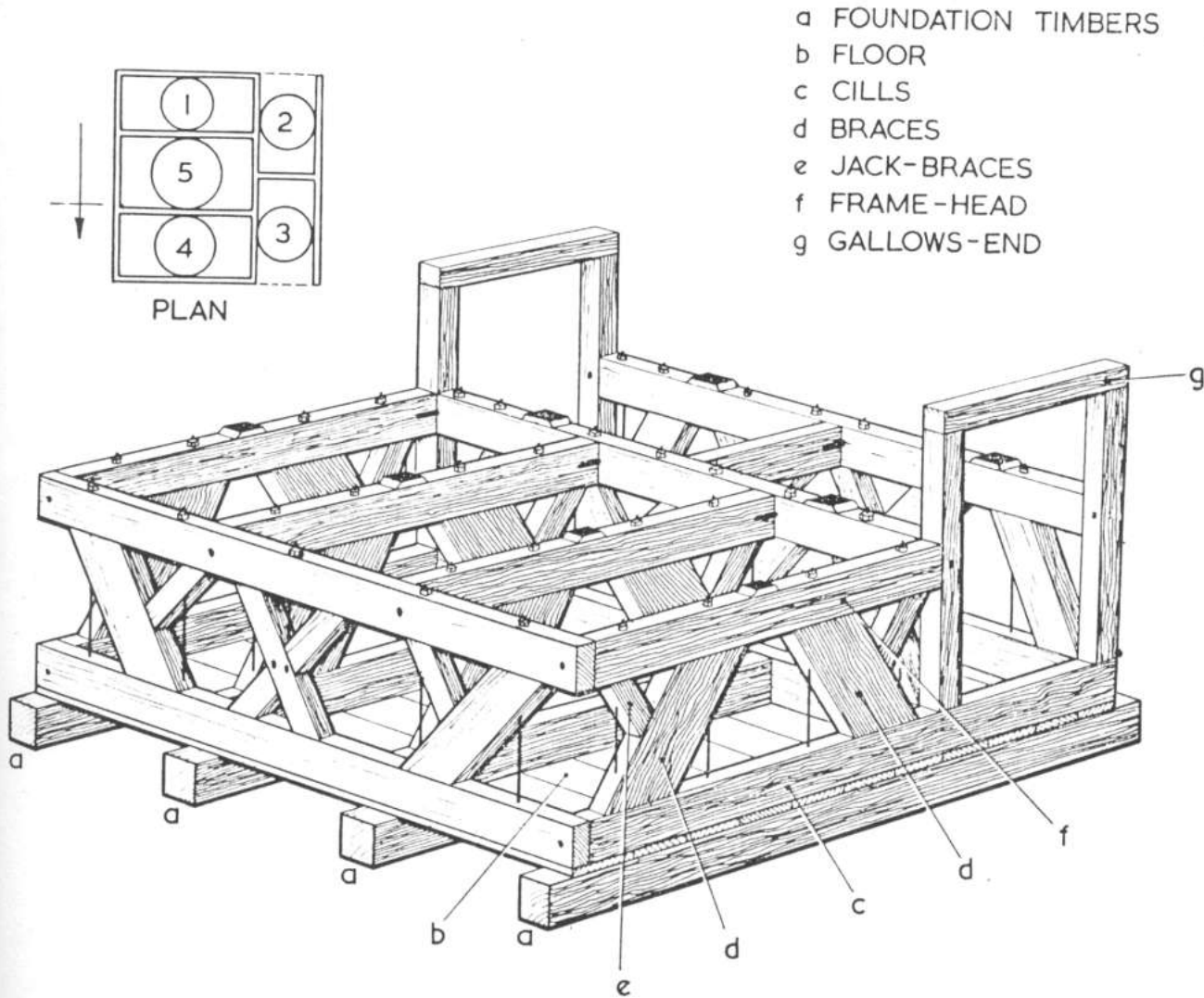

A typical long-headed frame (mainly post-medieval)

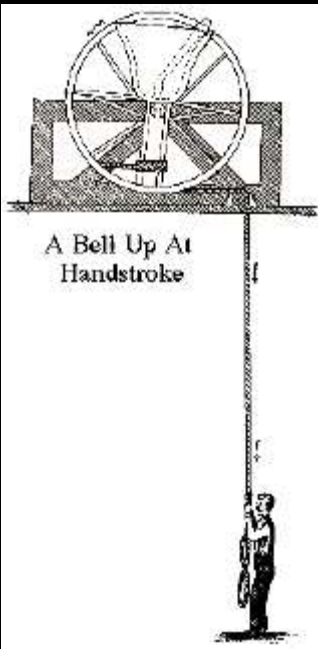
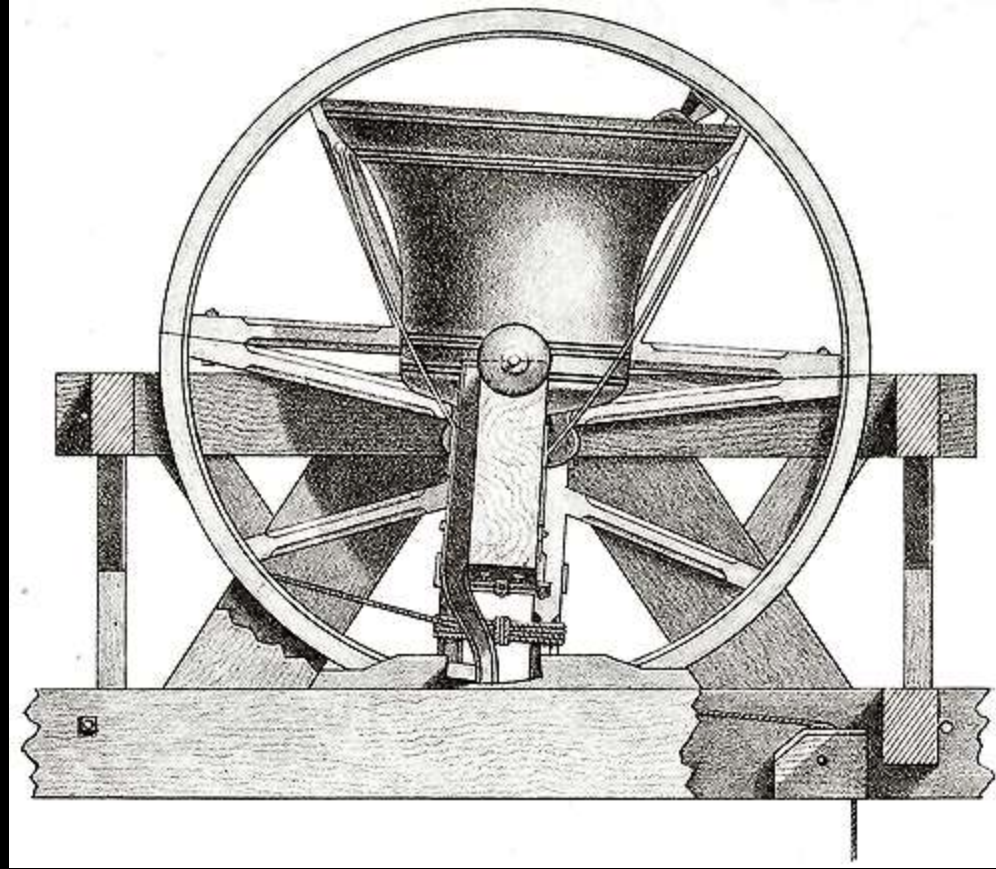
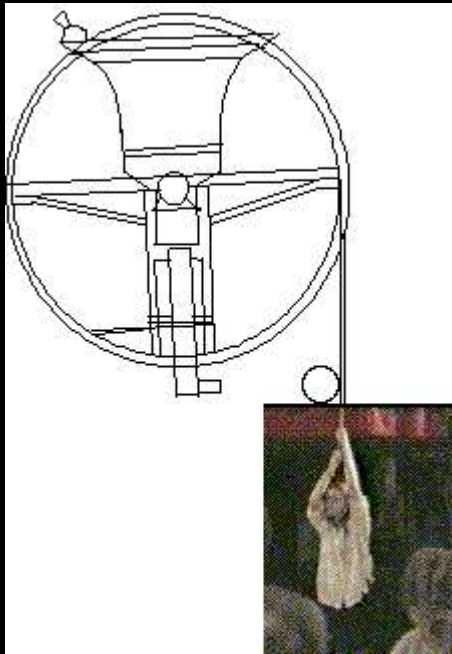

Full-circle or 'change' ringing -
Introduced in the early C17th

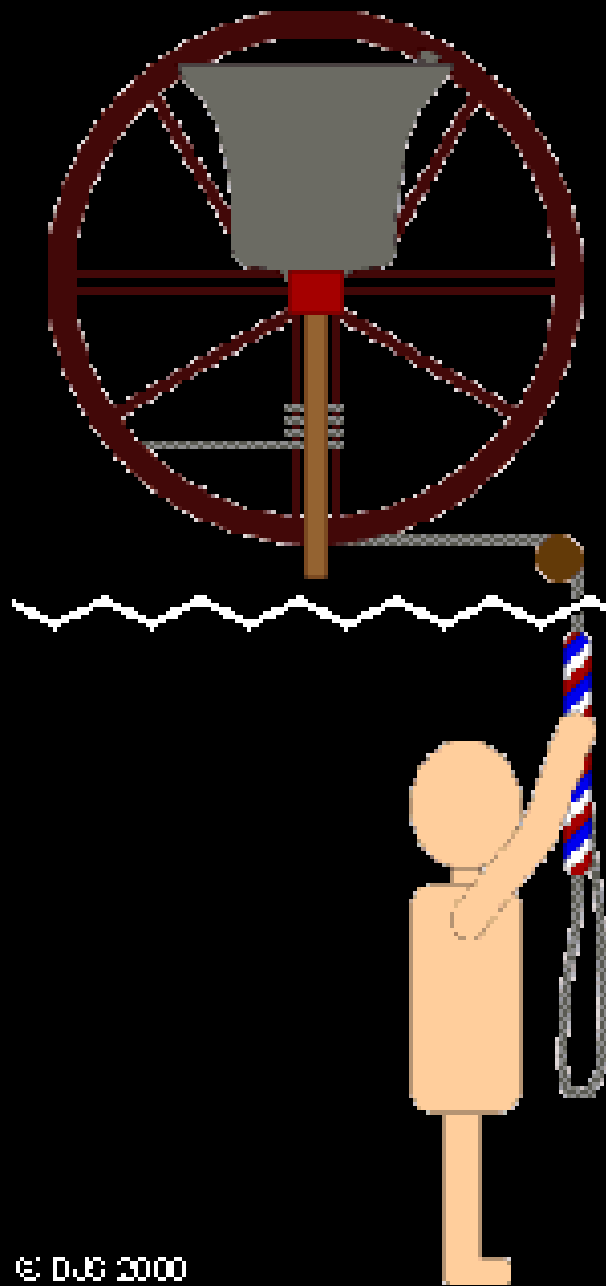

© DJG 2000

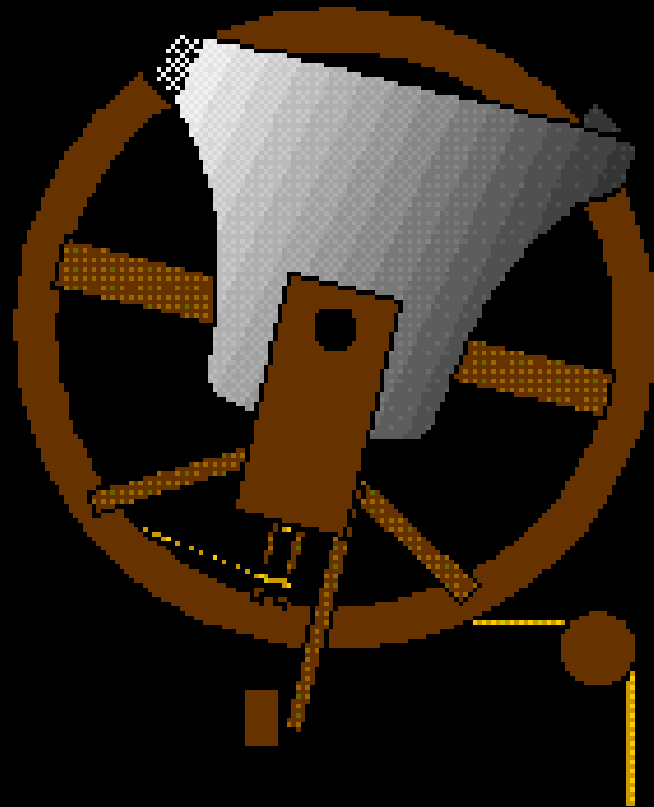

Plain Bob Triples

HL=7.1.7.1.7.1.7(127)(147)(12347)

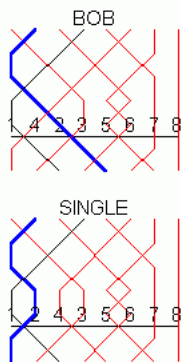
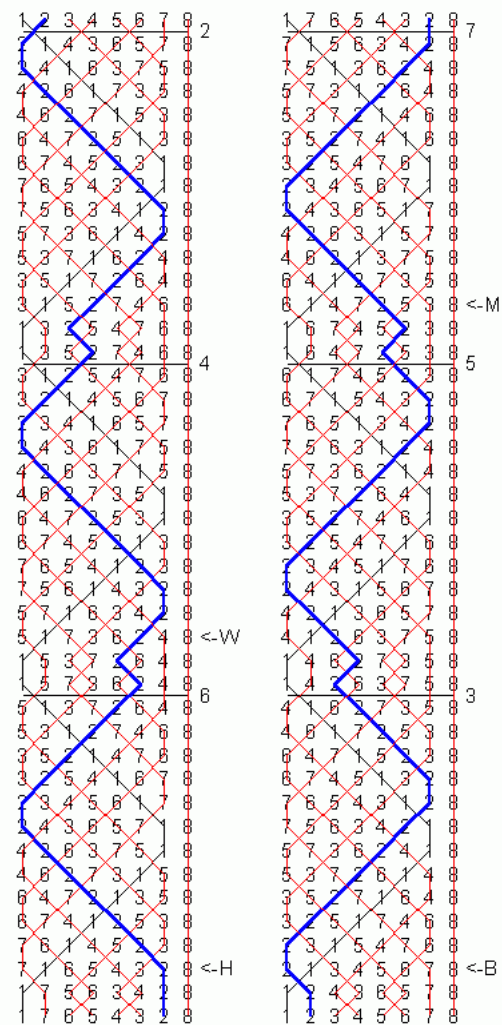

Plain Hunt notation

- Diagrams like this are often found chalked on the walls of ringing chambers



Fledborough: early form of Elphick 'V' frame with curved braces.
Undated but probably late medieval

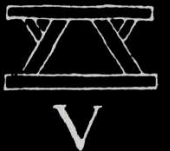

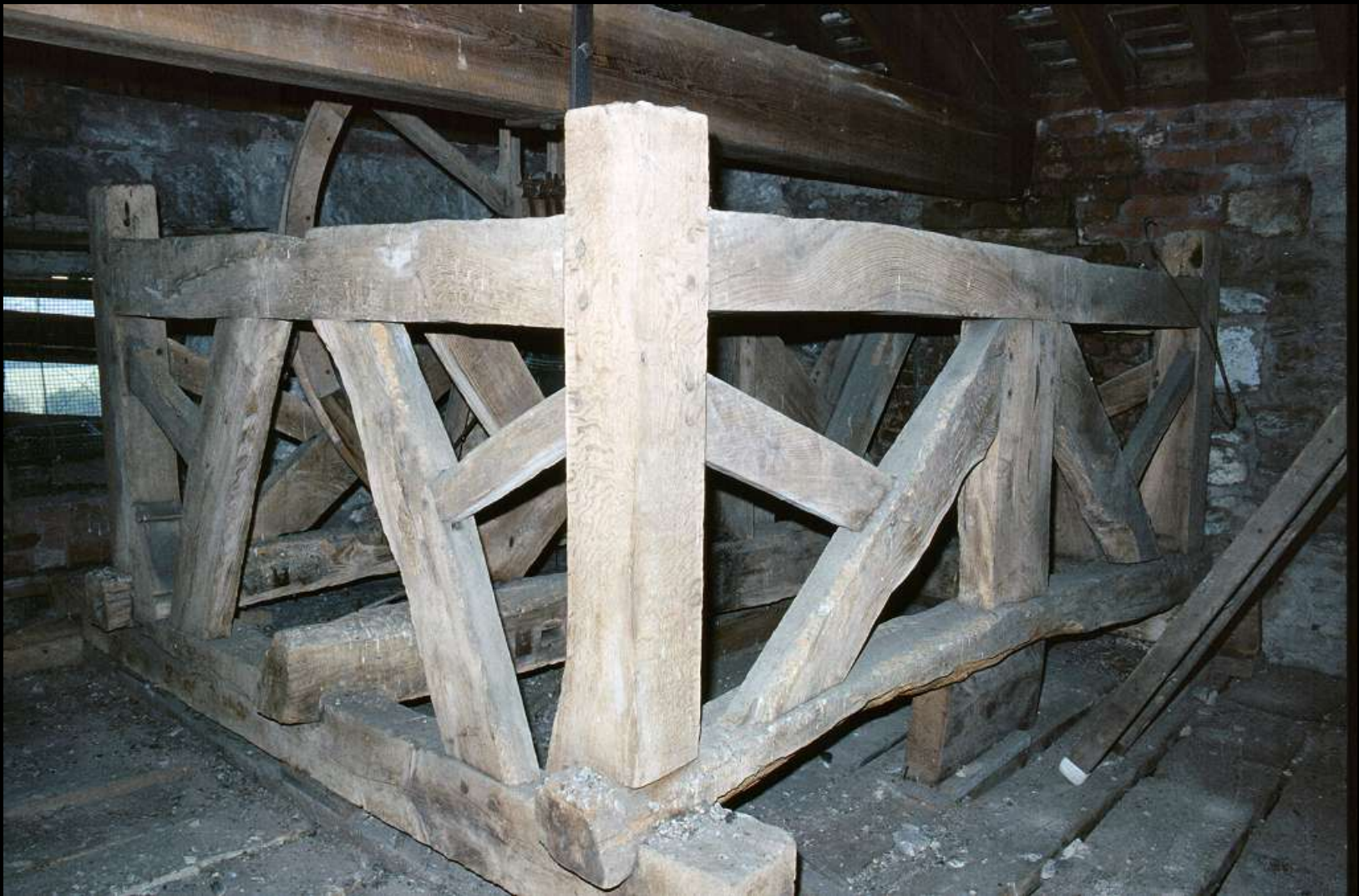

Headon: long-headed frame, Pickford type 5.F variant and type 6.C. Date unknown, possibly late medieval.





Typical Elphick 'V' trusses in an empty pit at Cromwell. Undated, possibly early post-medieval

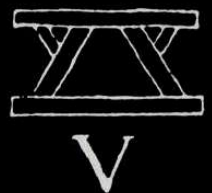



Probable post-medieval bellframe, Elphick type W from Farndon, St Peter.





Southwell Minster: bell frame of c. 1720
Elphick type 'V'; Pickford type 6.B

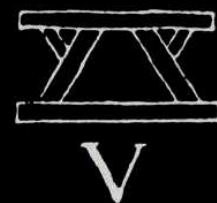

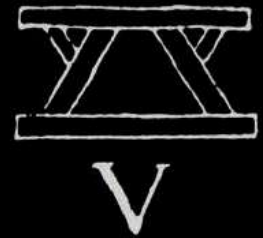
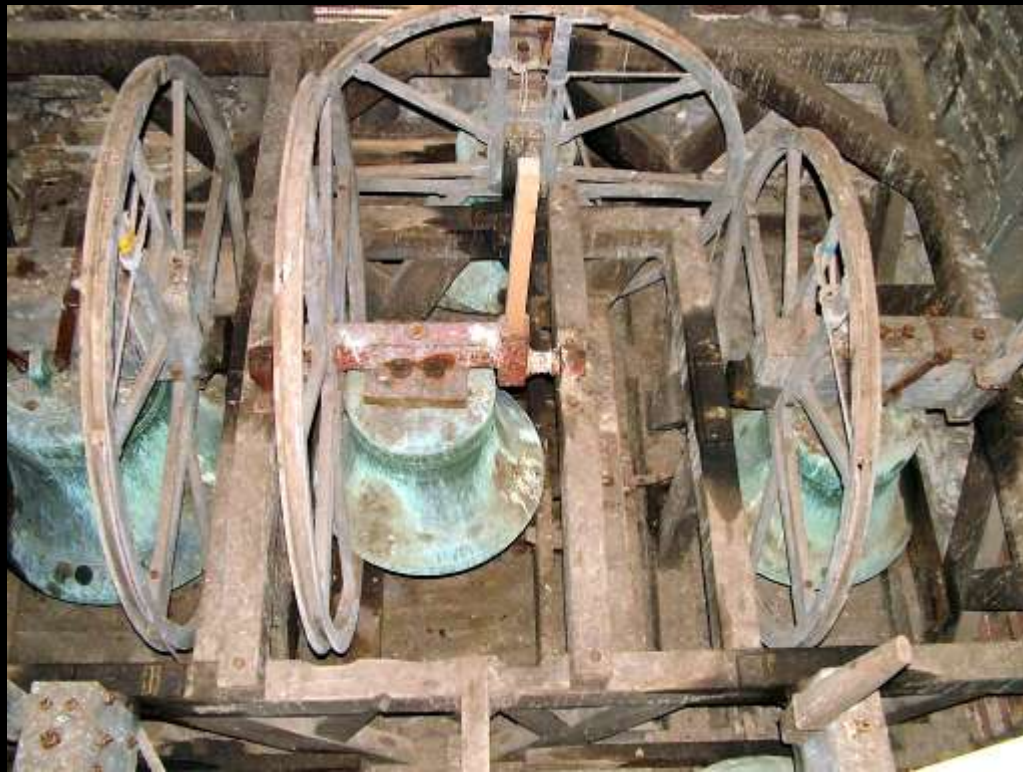

Averham: bellframe of
c.1840, Elphick 'V' form

Truss B-B

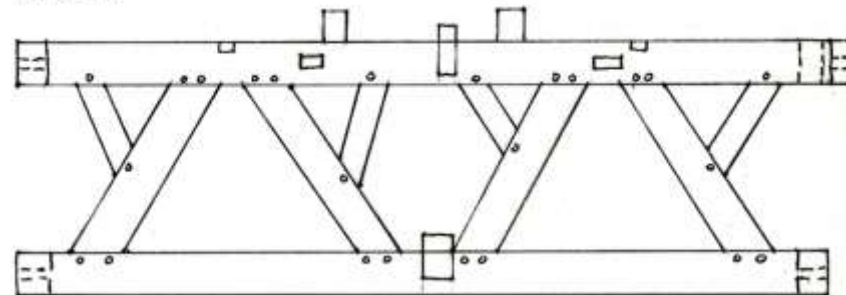

Truss C-C

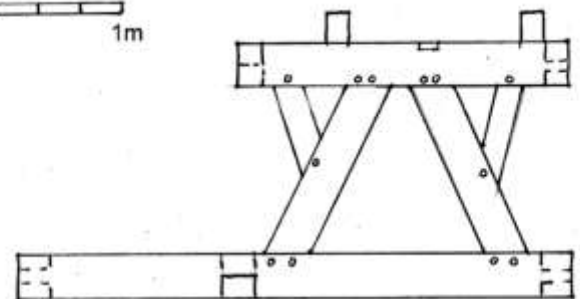



The classification system extends to cast-iron and other metal bellframes

8.1.F

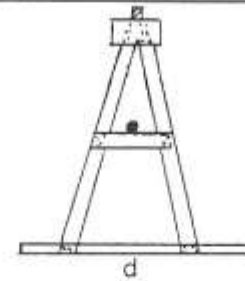

8.1.F

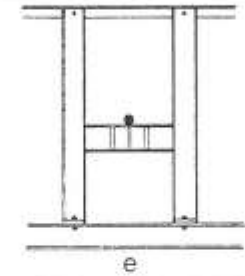

8.1.F

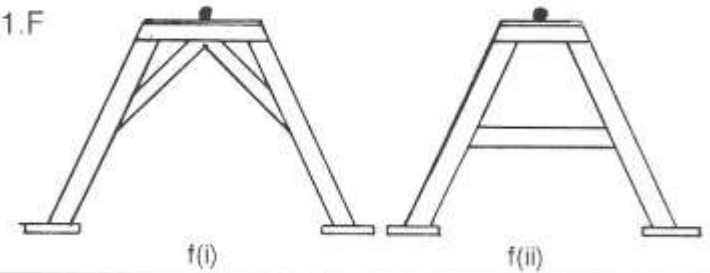

8.1.F

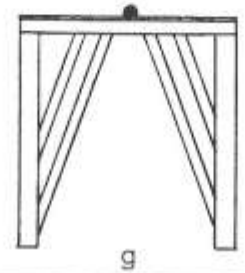



Turret-hung bells also have a classification – Elphick 'A' / Pickford Group 9.

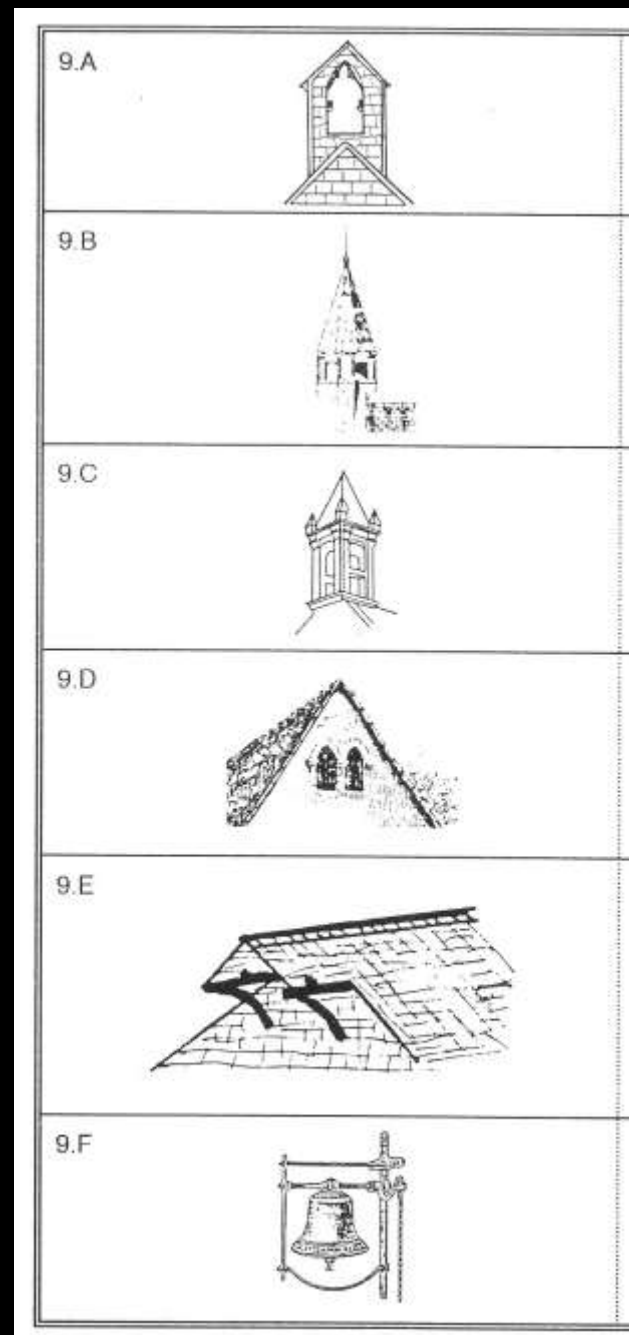

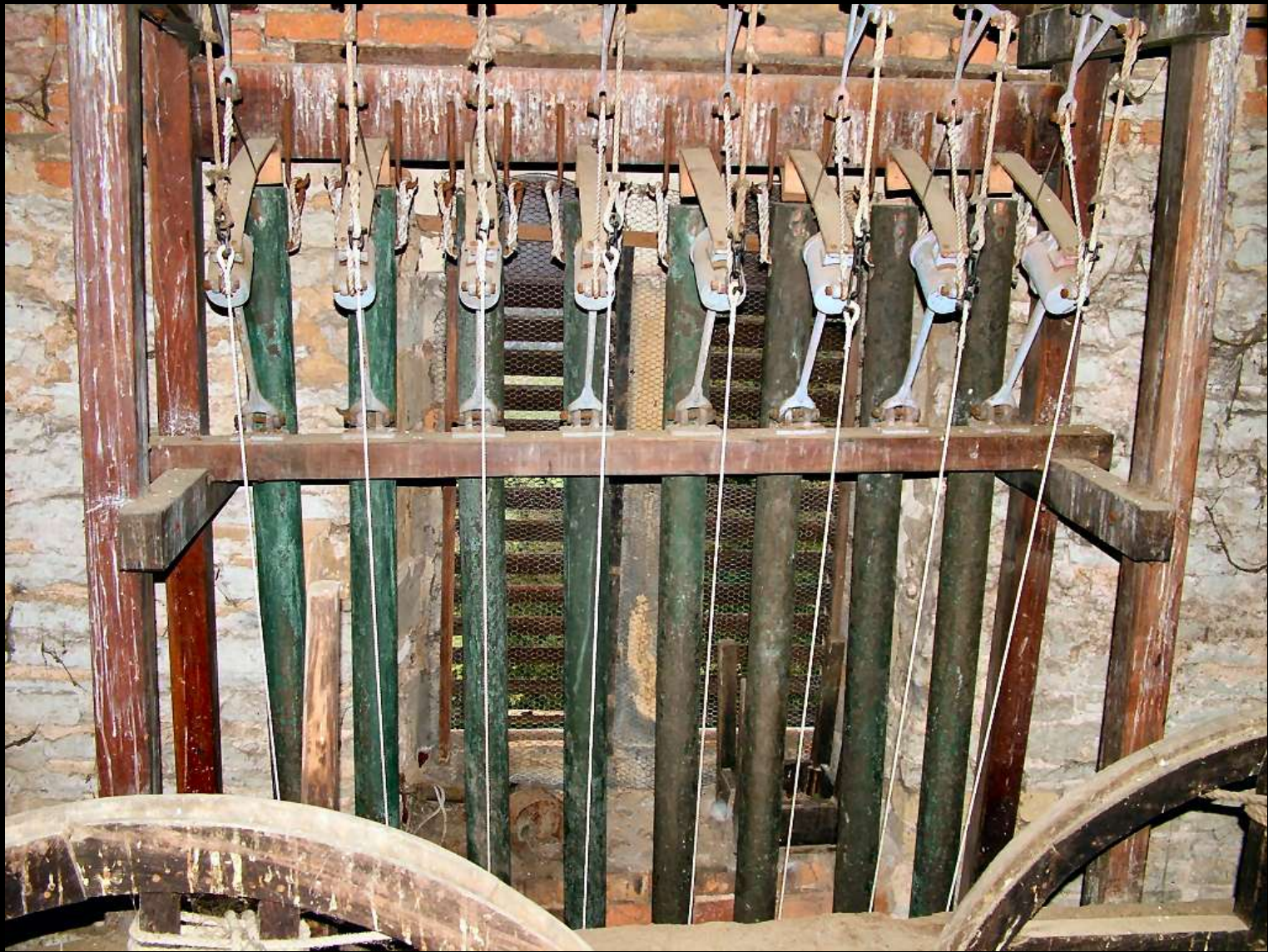

Bleasby – tubular bells 1911
to comemorate coronation of George V



Bell hoist pulley at Bleasby. Probably C19th.



Pembridge, Herefordshire.
Timber bell-house, late
C14th.



Yarpole, Herefordshire: separate bell-tower with complex internal timber structure, probably C13th, restored 1910.